

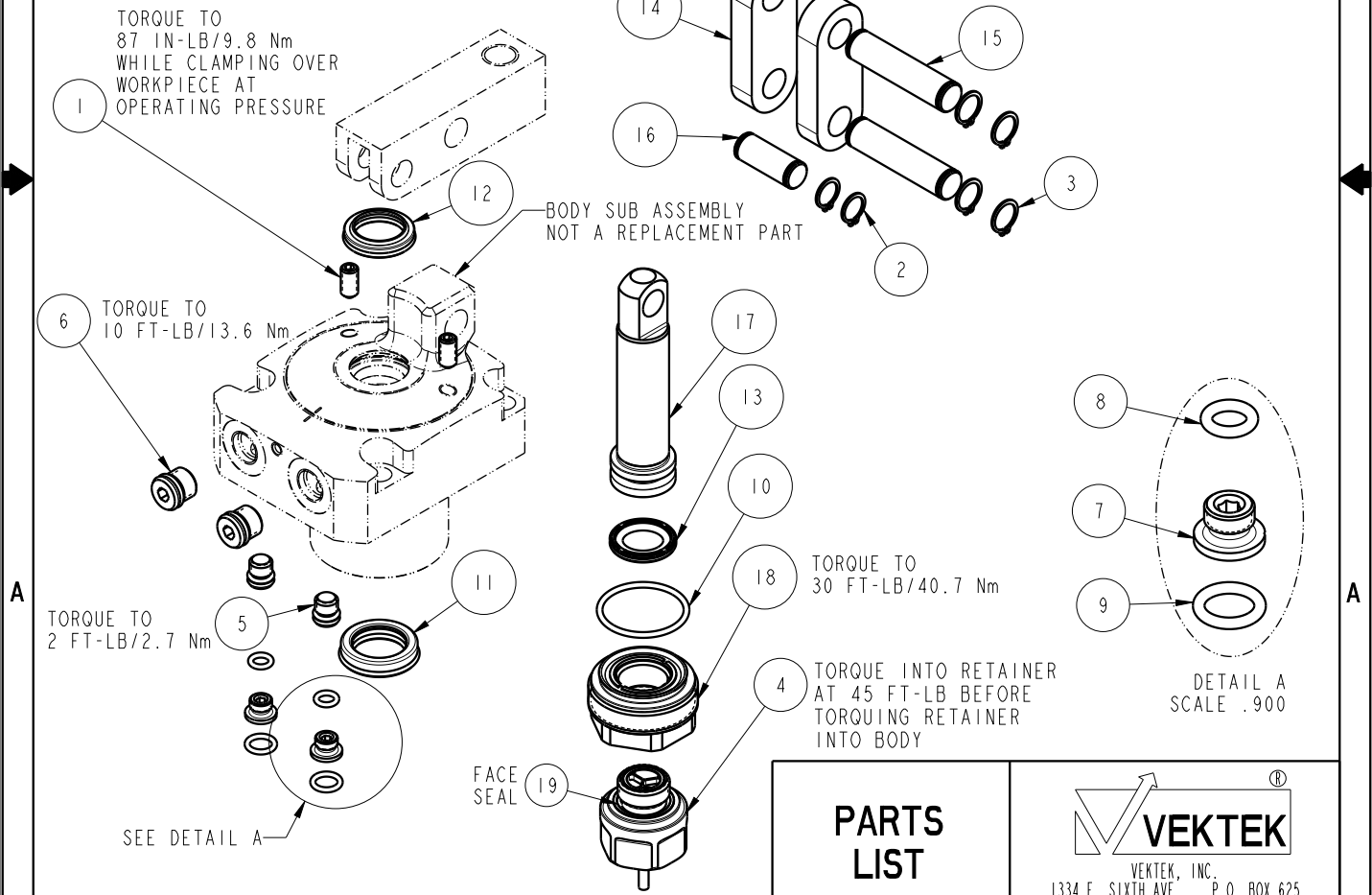

NO	QTY	PART NO	DESCRIPTION	STD SEAL KIT
1	2	21500319	SCREW, SET, CUP PT, M6 X 1 X 12	
2	2	23050036	RING, RTNG, EXT, 0.394	X
3	4	23050037	RING, RTNG, EXT, 0.438	X
4	1	29740200	SENSOR, ULTRASONIC, MI2, 1m	
5	2	30601122	PLUG, SOCH, SAE 2	
6	2	30601144	PLUG, SOCH, SAE 4	
7	2	30871120	ASSY, ADAPTER, SC, TF, MM	X
8	2	39050036	O-RING, (-009)	X*
9	2	39050042	O-RING, (-011)	X*
10	1	39051151	O-RING, (28mm X 2)	X
11	1	39052061	SEAL, ROD, RSD, 18, 85A, AU	X
12	1	39053042	SEAL, WIPER, SNAP IN, WED, 18, 94A, AU	X
13	1	39056033	SEAL, CAP, PISTON, 22.5, 94A, AU	X
14	2	81600148	LINK, LC, 7MPa, 50B	
15	2	81600153	PIN, LINK, LC, 7MPa, 50B	
16	1	81600158	PIN, PLUNGER, LC, 7MPa, 50B	
17	1	81600253	PLUNGER, LC, TL360, DA, 2400/10.4kN	
18	1	81600331	CAP, LC, TL360, 2400/10.4kN, US	
19	1	43000040	SENSOR, FACE SEAL	
N/A	N/A	60160203	KIT, SEAL,	NOTED

*NOTE: ITEMS INCLUDED IN NO. 7



PARTS LIST	 VEKTEK VEKTEK, INC. 1334 E. SIXTH AVE. P.O. BOX 625 EMPORIA, KS. 66801 U.S.A.	
	PARTS LIST, ASSY, LC, TL360, DA, 2400lb, US	
ASSEMBLIES AFFECTED 16-3222-00-US	SIZE A	PL1638
		REV A

A	5531	RELEASE	ALS	11/5/24
REV	IN ACCORDANCE WITH ECN	EFFECTIVE DATE	REVISED BY	DATE
DRW BY:	ALS	DRAWING STATUS: Released PRODUCTION APPROVED FOR RELEASED STATUS ONLY		
DATE:	10/4/24			